

# P-2000

## По вопросам продаж и поддержки обращайтесь:

Алматы (7273)495-231	Калининград (4012)72-03-81	Омск (3812)21-46-40	Сыктывкар (8212)25-95-17
Ангарск (3955)60-70-56	Калуга (4842)92-23-67	Орел (4862)44-53-42	Тамбов (4752)50-40-97
Архангельск (8182)63-90-72	Кемерово (3842)65-04-62	Оренбург (3532)37-68-04	Тверь (4822)63-31-35
Астрахань (8512)99-46-04	Киров (8332)68-02-04	Пенза (8412)22-31-16	Тольятти (8482)63-91-07
Барнаул (3852)73-04-60	Коломна (4966)23-41-49	Петрозаводск (8142)55-98-37	Томск (3822)98-41-53
Белгород (4722)40-23-64	Кострома (4942)77-07-48	Псков (8112)59-10-37	Тула (4872)33-79-87
Благовещенск (4162)22-76-07	Краснодар (861)203-40-90	Пермь (342)205-81-47	Тюмень (3452)66-21-18
Брянск (4832)59-03-52	Красноярск (391)204-63-61	Ростов-на-Дону (863)308-18-15	Ульяновск (8422)24-23-59
Владивосток (423)249-28-31	Курск (4712)77-13-04	Рязань (4912)46-61-64	Улан-Удэ (3012)59-97-51
Владикавказ (8672)28-90-48	Курган (3522)50-90-47	Самара (846)206-03-16	Уфа (347)229-48-12
Владимир (4922)49-43-18	Липецк (4742)52-20-81	Саранск (8342)22-96-24	Хабаровск (4212)92-98-04
Волгоград (844)278-03-48	Магнитогорск (3519)55-03-13	Санкт-Петербург (812)309-46-40	Чебоксары (8352)28-53-07
Вологда (8172)26-41-59	Москва (495)268-04-70	Саратов (845)249-38-78	Челябинск (351)202-03-61
Воронеж (473)204-51-73	Мурманск (8152)59-64-93	Севастополь (8692)22-31-93	Череповец (8202)49-02-64
Екатеринбург (343)384-55-89	Набережные Челны (8552)20-53-41	Симферополь (3652)67-13-56	Чита (3022)38-34-83
Иваново (4932)77-34-06	Нижний Новгород (831)429-08-12	Смоленск (4812)29-41-54	Якутск (4112)23-90-97
Ижевск (3412)26-03-58	Новокузнецк (3843)20-46-81	Сочи (862)225-72-31	Ярославль (4852)69-52-93
Иркутск (395)279-98-46	Ноябрьск (3496)41-32-12	Ставрополь (8652)20-65-13	
Казань (843)206-01-48	Новосибирск (383)227-86-73	Сургут (3462)77-98-35	
Россия +7(495)268-04-70	Киргизия +996(312)-96-26-47	Казахстан +7(7172)727-132	

# P-2000 Digital Polarimeters

High-accuracy multi-option digital polarimeter for all applications.

## P-2000 Digital Polarimeters

The P-2000 is a configurable high precision digital polarimeter with many options for measurement range, sampling accessories and software applications. The P-2000 digital polarimeter can also be field upgraded as application requirements change. Optional wavelength filters and source lamps cover a wide range of analytical wavelengths from UV-Visible to NIR in addition to the traditional sodium (589nm) lamp used for regulatory compliance.

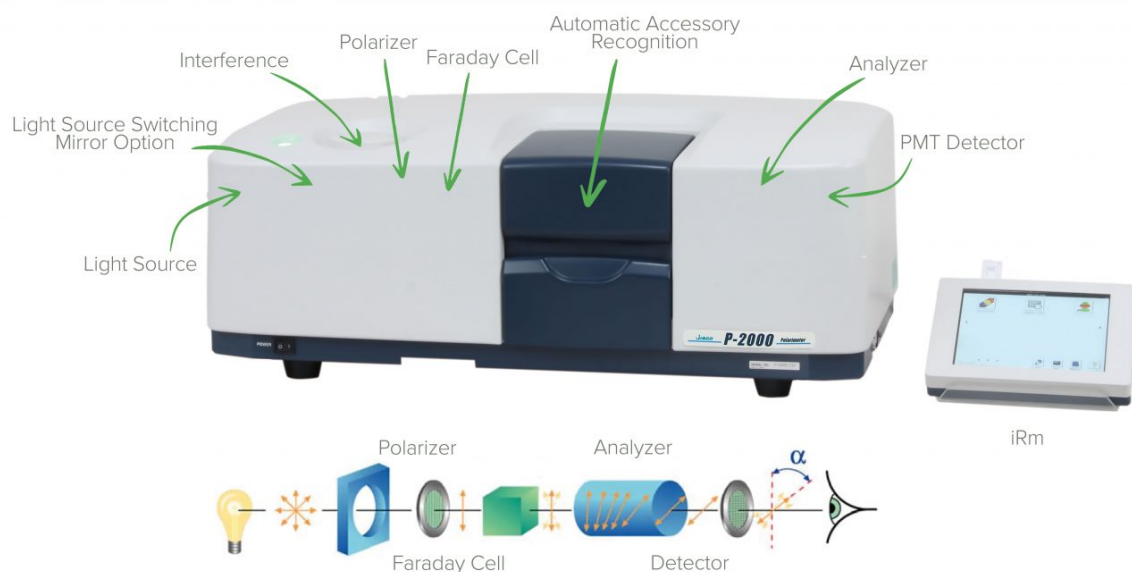

*Schematic of the P-2000 Digital Polarimeter*

## System Features

### Simple operation

Spectra Manager™ Suite for has a simple user interface operating and measurement. Where a PC is not required, a second option is the intelligent remote module (iRm) with color LCD touch screen. Spectra Manager CFR is used where regulatory compliance to 21 CFR part 11 is required.

### Light sources

For full compliance a sodium lamp (Na589) is the preferred option, but measurement to compliance standards can be made with tungsten halogen (WI) lamp and high quality band pass filter. The third choice is a mercury (Hg) lamp that can be used with a number of intense emission lines for wavelength from visible to UV.

### High Speed, Precision and Accuracy

For fast measurement, the P-2000 has a response speed of up to 6° per second, to a resolution of 0.0001°. The wide dynamic range from 0.001° to ±90° enables measurement over a very broad range of concentrations. The sample chamber includes temperature measurement with the actual temperature constantly updated and displayed on the control screen.

## Accessories

For a diverse range of sample types and measurements, the accessories and cells include many different options: a range of cylindrical and demountable stainless steel cells, a Peltier thermostatted cell holder and monochromator options. Quick-connect fittings with flow control valves are used for simple exchange of water jacketed cells for use with water circulators.

## Validation and Regulatory Compliance

The automated validation program is compliant with the requirements of GLP/cGMP, USP and FDA. Validation is used for automated periodic testing of light source energy, zero repeatability, and rotational accuracy/repeatability. For guaranteed measurement accuracy, filters and sample cells with certified optical path length can be used and NIST-traceable calibration standards are also available.

Principle	Automatic digital polarimeter with symmetric angular oscillation using the optical-null balance method
Light Source	Tungsten-Halogen lamp (W), Sodium lamp (Na), Mercury lamp (Hg) (Up to two light sources can be installed.)
Modulator	Faraday cell
Wavelength	253, 280, 296, 313, 302, 325, 334, 365, 405, 436, 546, 578, 589, 633, 880 nm
Aperture	1.8, 3 and 8 mm diameters
Angular Range	±90°
Response Speed	6°/sec
Measurement Accuracy	±0.002° (up to 1°)
Repeatability	±0.2% (larger than 1°) 0.002°
Resolution	0.0001°
Integration Time	1 - 100 sec
Detector	Photomultiplier tube (1P28-01) (R928 - option)
Readout Modes	Optical rotation, optical specific rotation, concentration, sugar scale Z, Brix purity, optical purity
Temperature Measurement Range	0~40°C (minimum display temperature: 0.1°C)
Dimensions	653 (W) x 249 (D) x 364 (H) mm
Weight	Approx. 30 kg
Power Requirement	AC100~240V ±10%, 50 or 60 Hz, 80 - 300 W

## Ultimate Flexibility

The P-2000 Digital Polarimeter provides a large choice of control system, light source, cell, cell holder and wavelengths ranging from the UV-Visible to NIR. The system most suitable for almost any requirement can be configured for the customer. A client can have the simplest system which includes those items required for his application.

## Light Sources

- Up to two light sources can be installed inside the instrument
- Automatic light source recognition
- Light source can be easily changed in the field



## Filters

- A range of available filters covers a wide range of applications
- Automatic filter recognition
- The optional wavelength extension kit enables measurements from UV-Visible (254 nm) to NIR (880 nm)

## Examples of Versatile System Configurations

### Single Wavelength System

546 nm with Hg or WI lamp

589 nm with Na or WI lamp

### Dual Wavelength System

589/546 nm with Na/Hg or WI lamp

### 5 Wavelength System

589/578/546/436/365 nm with Na/Hg lamps

### 6 Wavelength System

633/589/546/436/405/365 nm with WI lamp

### 7 Wavelength System

633/589/578/546/436/405/365 nm with WI lamp

### System Expansion to UV Range

334/313/302/296/280/254 nm with Hg lamp with the wavelength expansion option for the UV range

334/325 nm with WI lamp with the wavelength expansion option for the UV range

### Multiple Wavelength System for UV-Visible Range

633/589/578/546/436/405/365/334/325 nm with WI lamp with the wavelength expansion option for the UV range

### System Expansion to NIR Range

880 nm with WI lamp with the wavelength expansion option for the NIR range

### Multiple Wavelength System for NIR and Visible Range

880/589 nm with WI lamp with the wavelength expansion option for the NIR range

880/589/546 nm with WI lamp with the wavelength expansion option for the NIR range

## Digital Polarimeter P-2000 WI

The P-2000 WI system includes a tungsten halogen lamp and 589 nm interference filter for routine pharmaceutical measurements with the flexibility to add additional filters as applications and needs grow.

Available interference filters: 880, 633, 589, 578, 546, 436, 405, 365, 334, 325 nm

*All P-2000 digital polarimeters are iRM and PC compatible and 21CFR Part 11 optional.*



## Digital Polarimeter P-2000 Hg

The P-2000 Hg system couples a mercury lamp and 6 interference filters that span the visible to UV region for more analytically demanding laboratories.

Available interference filters: 578, 546, 436, 405, 365, 334, 313, 302, 296, 280, 253 nm

*All P-2000 digital polarimeters are iRM and PC compatible and 21CFR Part 11 optional.*



## Digital Polarimeter P-2000 Na<sup>+</sup>

For users requiring purity and identification measurements of pharmaceuticals and sugars using the 589 nm D-line of the sodium lamp.



*All P-2000 digital polarimeters are iRM and PC compatible and 21CFR Part 11 optional.*



# Digital Polarimeter Sippers

## Sippers

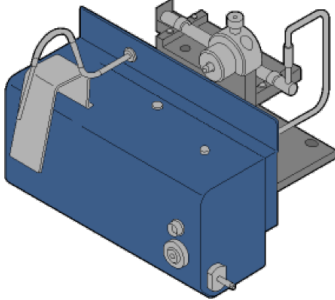
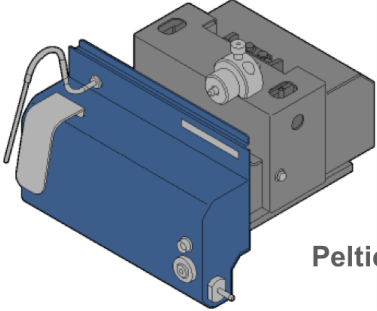
- The sipper offers quick and easy measurements of multiple samples
- Built-in ultra micro-pump for automated sampling of small volume samples

	<b>SHP-201 Sipper</b> Room Temperature	<b>SHP-201P Peltier Sipper</b> Temperature Control by Peltier
		 <b>Peltier</b> 
<b>Flow Cell</b>	100 mm pathlength	
<b>Minimum Sample Volume</b>	5 mL	
<b>Temperature Range</b>	-	15 ~ 40°C
<b>Temperature Accuracy</b>	-	± 0.2°C

# P-2000 Polarimeter Cell Holders

The room temperature cell holder can be used with a wide range of cells, including water-thermostatted cells for temperature controlled measurement with a water circulator. Quick-connect fittings with stop valves in the sample compartment offer simple and secure exchange of different cells. The Peltier cell holder offers fast and accurate temperature control with  $\pm 0.1^\circ\text{C}$  accuracy.

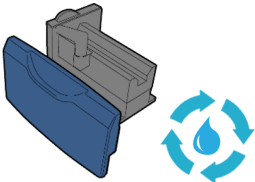
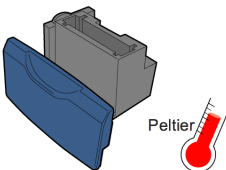
<b>RSC-200</b> Room Temperature Cell Holder	<b>PTC-262</b> Peltier Cell Holder	
 The RSC-200 is a blue plastic cell holder with a grey sample compartment. It is shown next to a blue circular icon with three arrows, representing water circulation.	 The PTC-262 is a blue plastic cell holder with a grey sample compartment. It is shown next to a red thermometer icon with the word 'Peltier' written next to it, indicating temperature control.	
<b>Temperature Control</b>	None (Water Circulation Optional)	<b>Peltier (Air Cooled)</b>
<b>Range</b>	-	15-40°C
<b>Accuracy</b>	-	$\pm 0.1^\circ\text{C}$
<b>Cell Diameter</b>	10 mm, 3.5 mm, 2.5 mm	
<b>Cell Pathlength</b>	100 mm, 50 mm, 10 mm	

**По вопросам продаж и поддержки обращайтесь:**

Алматы (7273)495-231  
Ангарск (3955)60-70-56  
Архангельск (8182)63-90-72  
Астрахань (8512)99-46-04  
Барнаул (3852)73-04-60  
Белгород (4722)40-23-64  
Благовещенск (4162)22-76-07  
Брянск (4832)59-03-52  
Владивосток (423)249-28-31  
Владикавказ (8672)28-90-48  
Владимир (4922)49-43-18  
Волгоград (844)278-03-48  
Вологда (8172)26-41-59  
Воронеж (473)204-51-73  
Екатеринбург (343)384-55-89  
Иваново (4932)77-34-06  
Ижевск (3412)26-03-58  
Иркутск (395)279-98-46  
Казань (843)206-01-48  
Россия +7(495)268-04-70

Калининград (4012)72-03-81  
Калуга (4842)92-23-67  
Кемерово (3842)65-04-62  
Киров (8332)68-02-04  
Коломна (4966)23-41-49  
Кострома (4942)77-07-48  
Краснодар (861)203-40-90  
Красноярск (391)204-63-61  
Курск (4712)77-13-04  
Курган (3522)50-90-47  
Липецк (4742)52-20-81  
Магнитогорск (3519)55-03-13  
Москва (495)268-04-70  
Мурманск (8152)59-64-93  
Набережные Челны (8552)20-53-41  
Нижний Новгород (831)429-08-12  
Новокузнецк (3843)20-46-81  
Ноябрьск (3496)41-32-12  
Новосибирск (383)227-86-73  
Киргизия +996(312)-96-26-47

Омск (3812)21-46-40  
Орел (4862)44-53-42  
Оренбург (3532)37-68-04  
Пенза (8412)22-31-16  
Петрозаводск (8142)55-98-37  
Псков (8112)59-10-37  
Пермь (342)205-81-47  
Ростов-на-Дону (863)308-18-15  
Рязань (4912)46-61-64  
Самара (846)206-03-16  
Саранск (8342)22-96-24  
Санкт-Петербург (812)309-46-40  
Саратов (845)249-38-78  
Севастополь (8692)22-31-93  
Симферополь (3652)67-13-56  
Смоленск (4812)29-41-54  
Сочи (862)225-72-31  
Ставрополь (8652)20-65-13  
Сургут (3462)77-98-35  
Казахстан +7(7172)727-132

Сыктывкар (8212)25-95-17  
Тамбов (4752)50-40-97  
Тверь (4822)63-31-35  
Тольятти (8482)63-91-07  
Томск (3822)98-41-53  
Тула (4872)33-79-87  
Тюмень (3452)66-21-18  
Ульяновск (8422)24-23-59  
Улан-Удэ (3012)59-97-51  
Уфа (347)229-48-12  
Хабаровск (4212)92-98-04  
Чебоксары (8352)28-53-07  
Челябинск (351)202-03-61  
Череповец (8202)49-02-64  
Чита (3022)38-34-83  
Якутск (4112)23-90-97  
Ярославль (4852)69-52-93